

Sumitomo Drive Technologies  
*Always on the Move*

# Paramax<sup>®</sup>

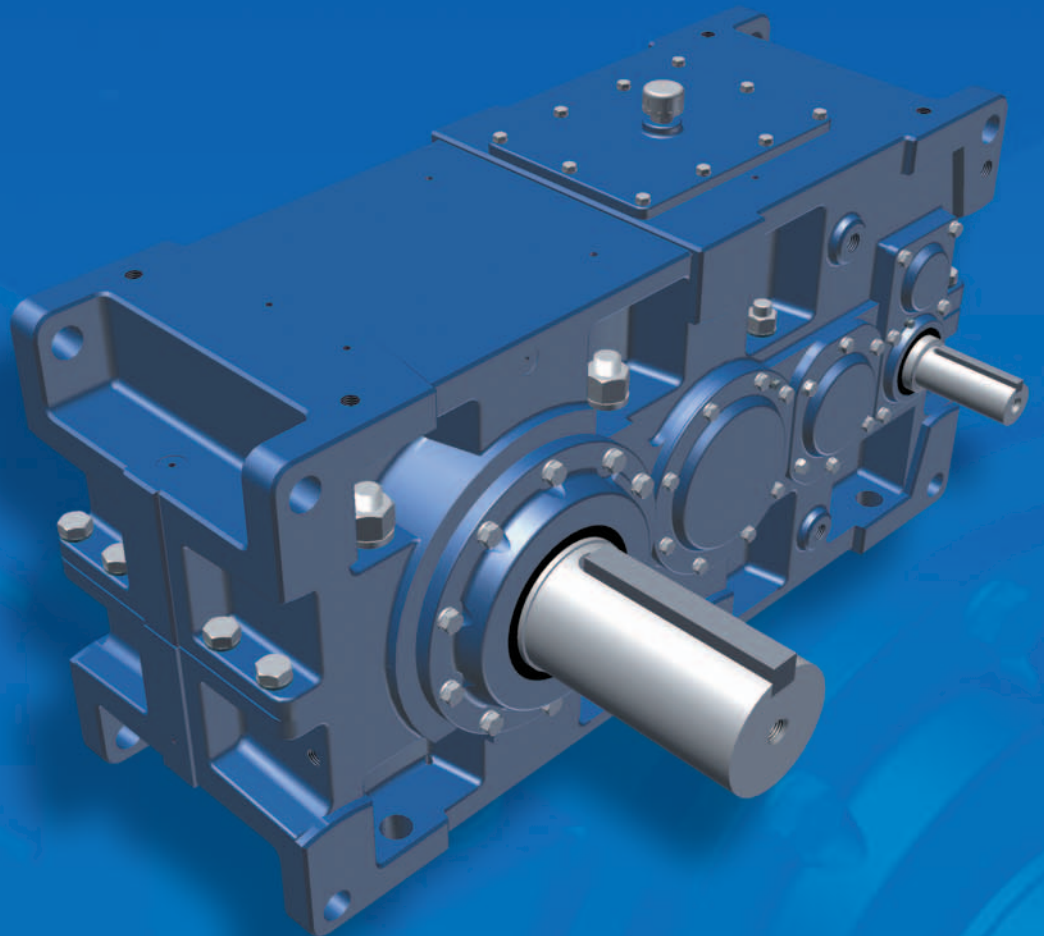

► Large Industrial Solutions

## ► **PX9000, the next generation speed reducer**

- Parallel and right angle configurations
- Solid and hollow shaft options
- Global availability through Sumitomo network

26 standard housing sizes for optimal selection

High tensile, low speed shaft material with wear sleeves for extended operation in aggressive environments

## Paramax® **9000**

Premier Performance, Industrial Gearbox in Universal Housing

- **Torque:** 23,000 to 5,000,000 lb-in
- Ratio:** 6.3:1 to 500:1

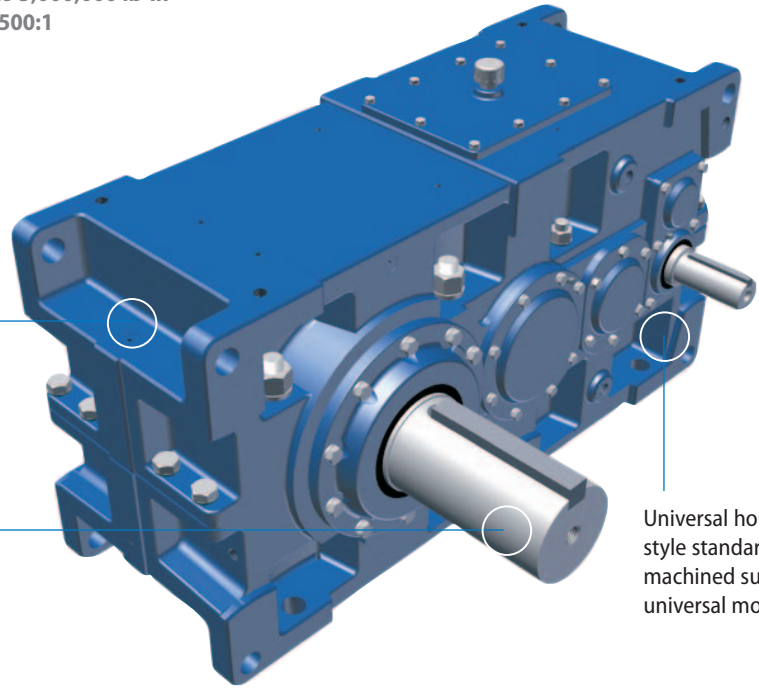

Universal housing style standard with machined surfaces for universal mounting

## ► **PX8000, the workhorse of the industry.** Paramax offers the most economical and finest quality products available.

- Significant interchangeability with PX9000 standard components
- Large installed base of successful applications
- Single reduction available

## Paramax® **8000**

Proven Design, Fast Delivery for Industrial & Commercial Large Industrial Drive Applications

- **Torque:** 20,000 to 5,000,000 lb-in
- Ratio:** 6.3:1 to 450:1

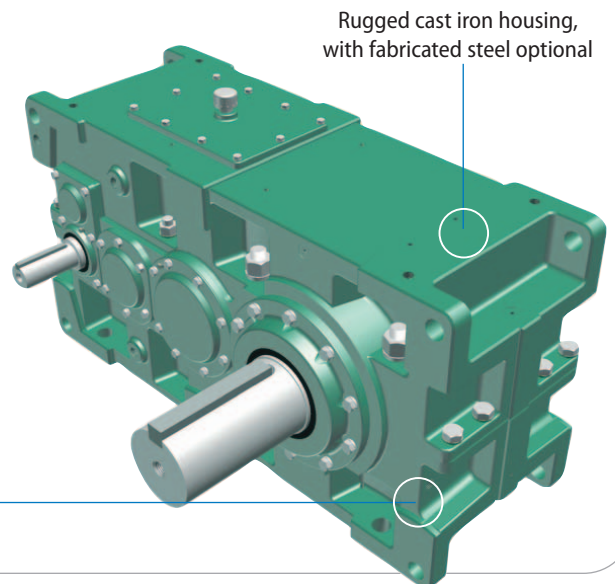

Rugged cast iron housing, with fabricated steel optional

20 standard housing sizes



► Visit [www.sumitomodrive.com](http://www.sumitomodrive.com) for the latest Large Industrial Drive Solutions

## Applications

- Cooling Towers and Condensers
- Extruders
- Agitators and Mixers
- Cement Kilns
- Cranes
- Wastewater Treatment
- Mining
- Forestry, Pulp and Paper
- Sugar Processing
- Material Handling

## Complete Drive Systems Solutions

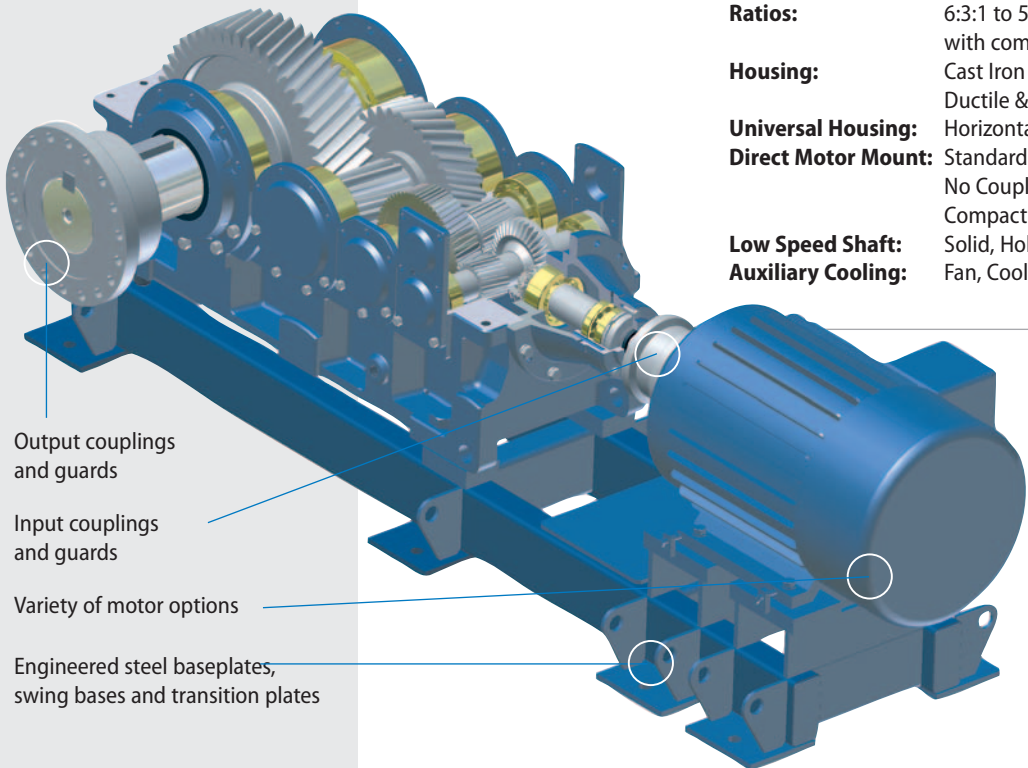

## Product Description

Paramax® parallel and right angle drives are built on almost six decades of Sumitomo excellence in power transmission engineering. Some of **the largest, and most durable power transmission systems operating in the world** were designed and manufactured by Sumitomo. The Paramax® product line includes the Standardized Series 9000, and the Special Application Series: SFC Cooling Tower and Condenser Drives, and SEC Extruder Drives.

## Standardized Series 9000

With 26 standard housing sizes, application of a Paramax® 9000 unit is optimized for precise horsepower, torque, speed and duty cycle, ensuring **long life and cost-effective**, efficient operation.

- 24 housing sizes for more precise unit selection and optimized applications
- High torque ratings, up to 5 million inch-pounds
- Higher ratings with a 25° pressure angle and wider gear tooth face
- Universal housings accommodate horizontal, vertical and upright installations
- Modular design concept allows direct motor mount for right angle designs
- New fan and shroud design delivers up to 87% increased thermal capacity, cooler operation and longer service life
- Optimized gear tooth profile for gearing accuracy, low wear, quiet and efficient operation
- Rugged cast iron housing is designed to minimize deflection under load
- Global standardization, availability and support from Sumitomo worldwide

## Specifications

- Torque Range:** 23,000 to 5 Million in-lbs (552,000 Nm)
- Ratios:** 6:3:1 to 500:1 standard. Unlimited ratios available with combination Cyclo® and Paramax®
- Housing:** Cast Iron (standard)  
Ductile & Fabricated Steel (optional)
- Universal Housing:** Horizontal, Vertical and Upright Mounting
- Direct Motor Mount:** Standard (for Right Angle Models)  
No Coupling Alignment  
Compact Design
- Low Speed Shaft:** Solid, Hollow Bore with Shrink Disc or Keyed
- Auxiliary Cooling:** Fan, Cooling Coil, Cooling Systems



**Paramax Signature Service** is a free program specifically created for each new Paramax product. When subscribing to Signature Service, you will receive:

- Extended Warranty
- Gear System Data Sheet
- Oil Analysis Kit

